



carmanah®

MODEL

M502



Solar-Powered LED Marine Lanterns

Carmanah's Model M502 solar marine lantern offers excellent value and extremely reliable operation for up to five years. With a virtually indestructible design, the Model M502 solar marine lantern is completely waterproof, vibration proof, and vandal resistant. As the next generation in Carmanah's popular, successful 500 series solar lanterns, the Model M502 includes all the features of its Model M501 predecessor, but is also completely programmable.

LIGHT OUTPUT AND OPERATION

Visibility ^{1,2}	1 NM (1.8 km)
Peak intensity (360-degree average, green LEDs)	~1.2 Candela
IP68 waterproof rating	Yes
Autonomy (flashing) at full charge	300 hours
Horizontal output	360°
Available LED color	Red, green, blue, amber, or white
Colored lens option	Yes
Flash patterns	7
Programmable (infrared)	Yes

CONSTRUCTION

Solar panels	Monocrystalline potted with UV-protected polyurethane and domed for higher efficiency
Light source	LED
Lens material	Polycarbonate
Battery (average 5-year life)	Non-replaceable
Battery amp-hour	2.5 Ah
Battery venting	Vent at the bottom of the lantern
Sealing	Self-contained unit, potted with polyurethane
MICROSOURCE®	No
Scheduled maintenance	None
Mounting options	2 Bolt
Weight	2.45 lb (1.1 kg)

TRADEMARKS, PATENTS AND APPROVALS

WEEE compliant	Yes
RoHS compliant	Yes
CE Approval	As per EN 60945:1997
Trademarks and patents	US Patents: 6573659 and 6013985 Other Patents Pending



Marine Clients

Australian Maritime Systems
 Brazilian Naval Commission
 Canadian Coast Guard
 CETMEF, France
 Indian Port of Kandla, India
 Maritime and Port Authority of Singapore
 NOAA – National Data Buoy Center
 Panama Canal
 Suez Canal, Egypt
 Trinity House Lighthouse Service, UK
 United States Coast Guard
 Vancouver Port Authority

Carmanah Technologies Corporation

Building 4-203 Harbour Rd.
 Victoria, BC V9A 3S2

Toll Free: +1.877.722.8877
 (US & Canada)

Worldwide: +1.250.380.0052

Fax: +1.250.380.0062

Email: info@carmanah.com

¹ Transmissivity of 0.74.

² Actual range is dependant on flash pattern, intensity, and LED color.

we put solar to work™

Solar-Powered LED Marine Lanterns Model M502



Side View

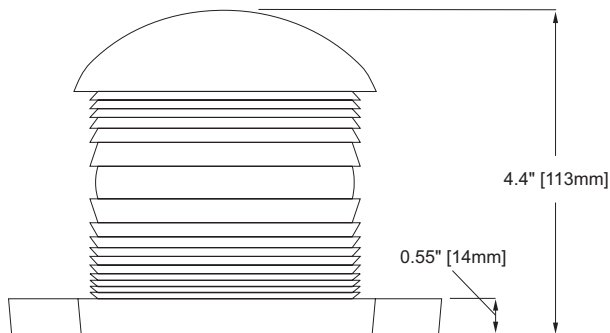

Top View

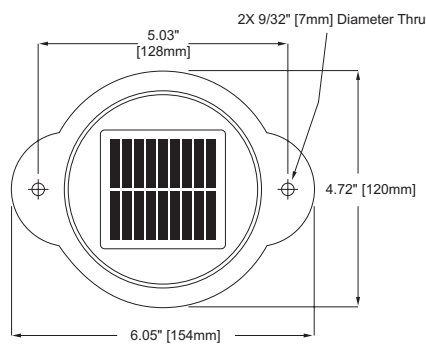

Accessories

Security Bolt



Mounting Plate



Carmanah's Model M502 solar marine lantern is a compact, light-weight, and low maintenance solution for marking small buoys, docks, marinas, aquaculture weirs, and other applications requiring navigation or hazard marking.

The Model M502 is the next generation of the Model M501 solar marine lantern which is installed in more than 110 countries. The Model M502 solar marine lantern features 1 NM (1.8 km) visibility and offers:

- **Maximum capacity with minimal life-cycle cost** – operates up to five years maintenance free *
- **Field-proven durability** – technology tested over 15 years
- **Passed extensive shock and vibration testing**
- **IP68 certification** – tested to higher levels of water ingress protection standards
- **Vandal and theft resistant design** – high quality construction and mounting hardware
- **Patented technology** – innovative LED technology and energy management system

The Model M502 is also:

- Manufactured in accordance with ISO 9001:2000 Quality Assurance Standards

* Dependent on location.



Toll Free Canada & US: 1.877.722.8877 • carmanah.com • Worldwide: +1.250.380.0052