

The BargeSafe™ Solar 2NM is a solar powered LED barge light. It is certified to UL 1104 and COLREG-72 compliant with 2NM visible range.

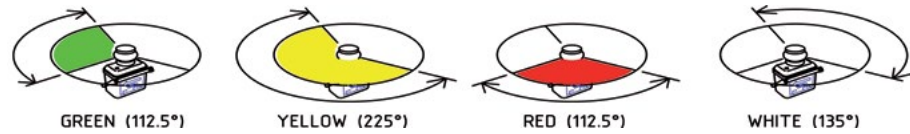

Key Features:

- 2NM visible range
- Precise intensity and sectoring from a single LED
- Ultra low power consumption
- Completely self-contained, solar panels charge the battery during daylight - activates automatically at dusk



Intensity Range

The BargeSafe™ Solar 2NM light utilises a single leading technology LED for a visible range of 2NM.

Enhanced Optics

The optics and lens design by Sealite's world-class engineering team.

Tough and Durable

Made from UV-stabilised polycarbonate – offering enormous impact resistance and long operational life. The casings are coloured for easy identification of light output colour.

Completely Self Contained

During daylight hours the solar module will charge the battery and the light will automatically begin operation at dusk – once the ambient light threshold drops sufficiently.

User Replaceable Battery

NiMH battery is replaceable and located in a sealed compartment. It offers a long service life and wide temperature range.

Easy Installation

Installs in minutes, requires no operator intervention and has a permanent ON/OFF switch for easy storage.





BargeSafe™ Solar 2NM

Light Characteristics

Light Source	1 ultra-high intensity LED
Available Colours	Red, Green, White, Yellow
Visible Range (NM)	AT @ 0.74: >2NM
	AT @ 0.85: >2.3NM
Horizontal Output (degrees)	Red - 112.5° Green - 112.5° White - 135° Yellow - 225° as per UL 1104 & COLREG-72.
LED Life Expectancy (hours)	>100,000

Electrical Characteristics

Circuit Protection	Integrated
Nominal Voltage (V)	3.6
Temperature Range	-40 to 80°C

Solar Characteristics

Solar Module Type	Monocrystalline
Output (watts)	1.6

Power Supply

Battery Type	High grade NiMH
Battery Capacity (Ah) - Standard - Large	8
	16
Nominal Voltage (V)	3.6
Autonomy (days)	>20

Physical Characteristics

Body Material	LEXAN® Polycarbonate – UV-stabilised
Lens Material	LEXAN® Polycarbonate – UV-stabilised
Lens Diameter (mm/inches)	150 / 5 7/8
Lens Design	Internal optics
Mounting	3 & 4 hole 200mm bolt pattern
Height (mm/inches)	122 / 4 7/8
Width (mm/inches)	231 / 9 1/8
Mass (kg/lbs)	1 / 2 1/4
Product Life Expectancy	Up to 12 years ^

Compliance

Approvals	UL 1104, COLREG-72
IALA	Signal colors compliant to IALAE-200-1
Ingress Protection	IP68

Intellectual Property

Trademarks	SEALITE® is a registered trademark of Sealite Pty Ltd BargeSafe™ is a trademark of Sealite Pty Ltd
Warranty *	1 year
Options Available	• 16Ah battery • 50mm pole mount adapter plate

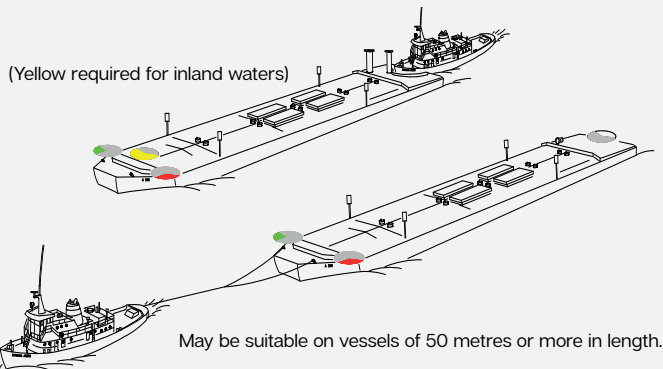

Ordering This Product

SL-BLS-2-[XX]-[X]



1 Product Number

2 Lens

3 Battery Options

B1 8Ah battery
B2 16Ah battery

4 Colour

W White
Y Yellow
G Green
R Red

Technical Illustrations

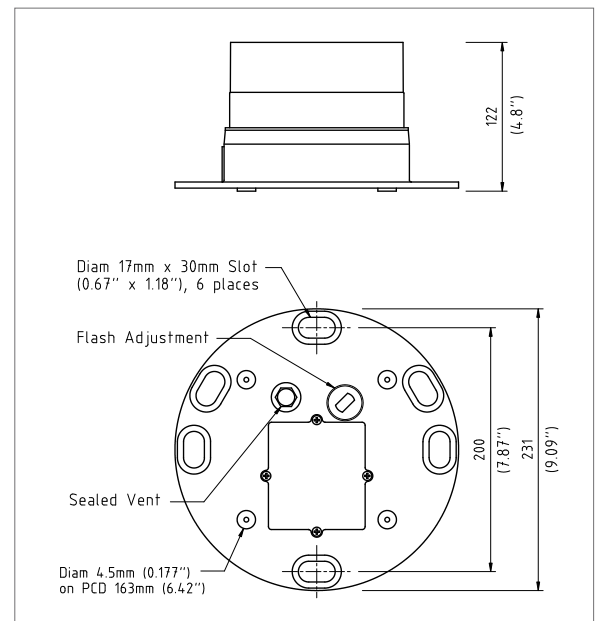

- Specifications subject to change or variation without notice
- * Subject to standard terms and conditions
- † Intensity setting subject to solar availability
- ^ Refer to the Sealite website under the warranty section

